

A High Sensitivity Detection Method of Singlet Oxygen and Superoxide Anion

Min HAO, Da XING*, Qun CHEN, Juan WANG

Institute of Laser Life Science, South China Normal University, Guangzhou 510631

Abstract: This paper, for the first time, reports a method that can be used as a highly sensitive probe for singlet oxygen ($^1\text{O}_2$) and superoxide anion (O_2^-) *in vitro* or *in vivo*. FCLA(3,7-dihydro-6-{4-[2-(N'-(5-fluoresceinyl)thioureido)ethoxy]phenyl}-2-methylimidazo{1,2-a}pyrazin-3-one sodium salt), a chemiluminescence (CL) analysis reagent, has been reported to sensitively react with $^1\text{O}_2$ and O_2^- to emit photons with a spectral peak of 525nm. In this work, when human serum albumin (HSA) was added into FCLA solution to enhance the CL intensity, approximately 20 times, compared to that without HSA. The enhanced CL had the same 525 nm spectral peak, identical to that without HSA. By gradually reducing the molecular oxygen content in the solution, we find that the auto-oxidation of oxygen molecules dissolved in the solution plays an important role in the CL process. Based on these experimental evidences, we propose a novel and highly sensitive detection method of $^1\text{O}_2$ and O_2^- , which may have a great potential in chemical and medical applications.

Keywords: Singlet oxygen, superoxide anion, chemiluminescence.

Reactive oxygen species (ROS) closely related to tissue damages and some diseases, accordingly, detection the generation, distribution and content of ROS inside biologic systems have great significance to fundamental and clinical researches¹. At present time, chemiluminescence (CL) is one of the most general methods in detecting ROS. The basic principle of this method is that, the free radical with elevated energy level can react with specific CL probe and produce an excited species in the process, then the excited species decay to the ground state by emitting photons. Based on this, we propose a novel and highly sensitive detection method of singlet oxygen ($^1\text{O}_2$) and superoxide anion (O_2^-), which may be applied in fundamental research of biomedicine in the future.

Experimental

Human serum albumin (HSA) was purchased from Sigma Chemical Co., FCLA (3,7-dihydro-6-{4-[2-(N'-(5-fluoresceinyl)thioureido)ethoxy]phenyl}-2-methylimidazo{1,2-a}pyrazin-3-one sodium salt) was obtained from Tokyo Kasei Kogyo Co. Ltd.

A custom-built weak-photon detection system was used to detect the CL. The heart of the setup was a PMT (MP962 model) that had a wavelength response range between 185-850 nm. A schematic setup of the system is given in **Figure 1**.

* E-mail: xingda@scnu.edu.cn

Figure 1 The schematic of single photon counting system

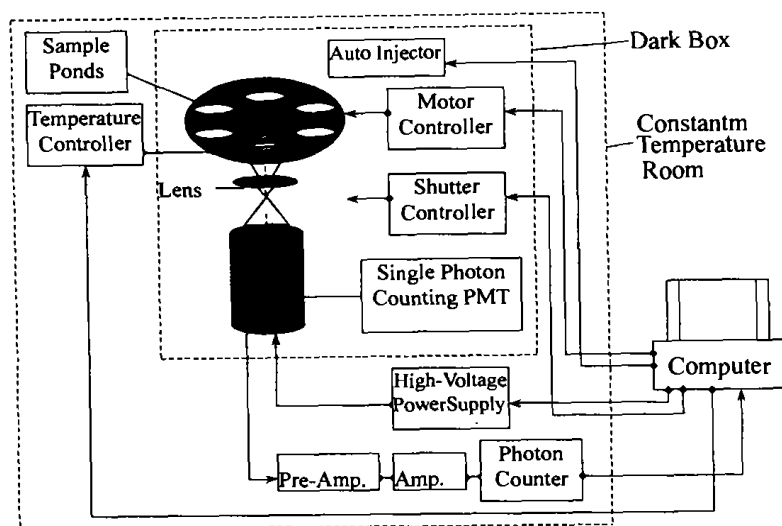

H₂O 200 μL+FCLA 100 μL and H₂O 100 μL +HSA 100 μL +FCLA 100 μL were added into two cells respectively, and the final concentration of FCLA is 5 μmol/L and HSA is 10 μmol/L. The CL of the two systems was detected and compared.

Results and Discussion

The result is showed in **Figure 2**. The curve A is the CL intensity of FCLA solution, and the curve B is the CL intensity of FCLA+ HSA system.

Figure 2 The CL of FCLA solution compared with FCLA-HSA system's

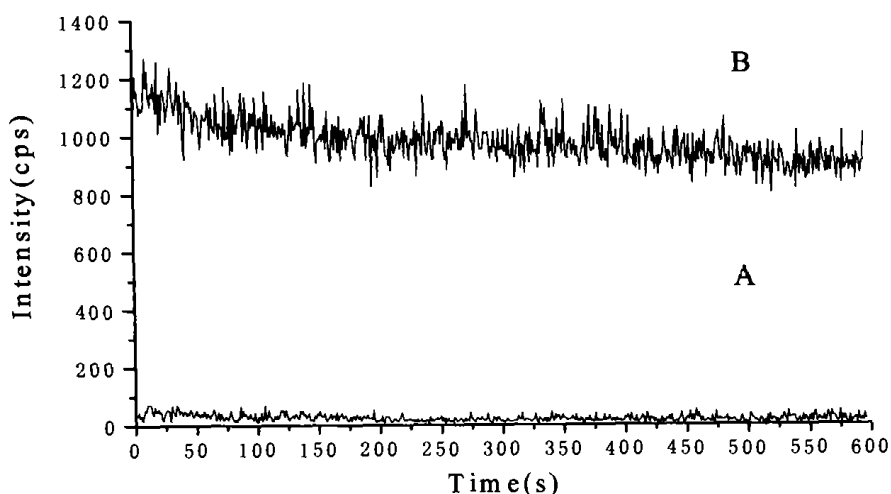

The result showed that the CL intensity of FCLA+ HSA system is 20 times stronger than the FCLA solution's. As a CL analysis reagent²⁻⁶, FCLA can sensitively react with ¹O₂ and O₂⁻. At natural oxygen partial pressure, FCLA reacted with ¹O₂ and O₂⁻ that derived from the oxygen molecules dissolved in the FCLA solution to produce weak CL. When HSA was added, the CL intensity was significantly enhanced about 20 times just as

the curve B showed, and had the same 525 nm spectral peak, identical to that without HSA. So we speculate that the HSA catalyzed the reaction of FCLA with $^1\text{O}_2$ and O_2^- , enhanced the detection sensitivity of FCLA.

Figure 3 The relationship between the oxygen content and CL intensity

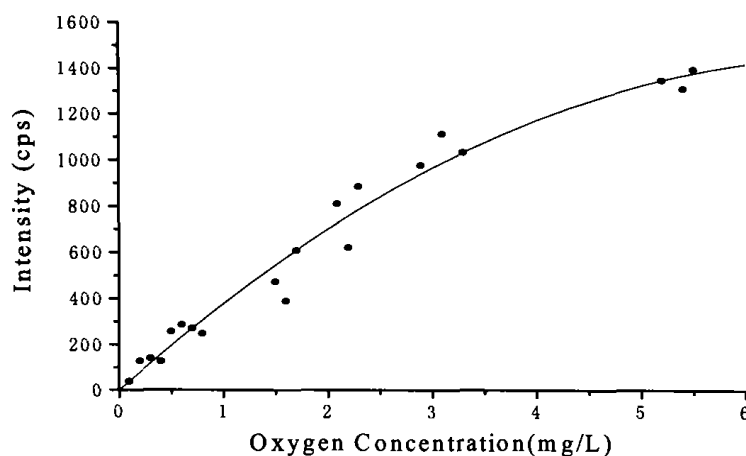

The deoxidization experiment of FCLA-HSA system demonstrates that solubility of the oxygen molecules in the solution plays a very important role to the production of CL. When the content of oxygen was reduced by blowing with N_2 until the oxygen concentration approaches to zero, CL almost disappeared. In this experiment we measured 20 data points and fit them to a multinomial equation (Figure 3). With the decrease of the oxygen content, the CL intensity of FCLA-HSA solution was also attenuated to zero, the CL disappeared simultaneously. The relationship between the oxygen content and CL intensity was linear. In fact the deoxidization cut off the transformation origin of $^1\text{O}_2$ and O_2^- , therefore that the CL intensity gradually weakened with the reduction of the oxygen content. This experiment proved the CL energy donor of FCLA-HSA system was $^1\text{O}_2$ and O_2^- , the chemiluminescent essential was that FCLA reacted with $^1\text{O}_2$ and O_2^- to produce CL.

Figure 4 Comparison the CL of FCLA solution with different albumin

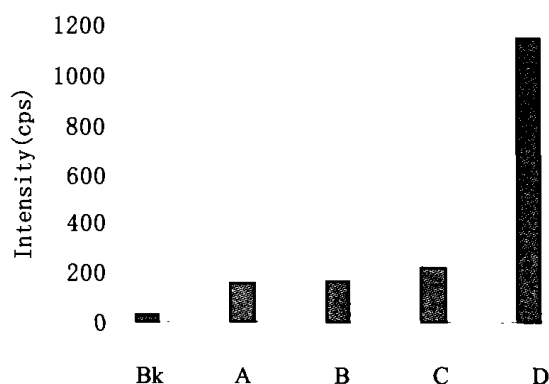

In order to testify whether other albumin has the same function that can enhance the CL of FCLA solution, some similar experiments had been done. In Figure 4 the CL

intensity of FCLA solution is regarded background (bk), the CL intensity of FCLA+ BSA (bovine serum albumin) system is the A column, the CL intensity of FCLA+ BS (bovine serum) system is the B column, the CL intensity of FCLA+ HS (human serum) system is the C column, and the CL intensity of FCLA+ HSA system is the D column. By comparing we discovered that all these biologic samples could enhance the CL of FCLA solution in various degree, the effect of HSA was the most obvious.

Conclusion

In this paper, we reports a high sensitive detection method for $^1\text{O}_2$ and O_2^- . The sensitivity of this method is about 20 times higher than the conventional method. HSA used in this experiment is a ubiquitous component in human organism, so it should have no toxicity. This method will have an enormous potential in fundamental research and clinical medicine.

Acknowledgments

This research is supported by the National Major Fundamental Research Project of China (2002CCC00400) and the Team Project of Natural Science Foundation of Guangdong Province (015012)

References

1. J. Wang, D. Xing, Y. He, X. Hu, *FEBS Lett.*, **2002**, 525 (1-3), 128.
2. S. Mashiko, N. Suzuki, S. Koga, M. Nakano, *et al.*, *J. Biolumin. Chemilumin.*, **1991**, 6, 69.
3. M. Nakano, K. Sugioka, Y. Ushijima, T. Goto, *Anal. Biochem.*, **1986**, 159, 363.
4. O. Shimomura, K. Teranishi. *Luminescence.*, **2000**, 15, 51.
5. K. Sugioka, M. Nakano, S. Kurashige, Y. Akuzawa, T. Goto. *FEBS Lett.*, **1986**, 197, 27.
6. Y. Yamamoto, Y. Kambayashi, T. Ito, K. Watanabe, M. Nakano. *FEBS Lett.*, **2001**, 412, 461.

Received 22 May, 2003